

DIESEL ENGINE-GENERATOR SET

60-JC6DT3

60 ekW / 60 Hz / Standby

55 ekW / 60 Hz / Prime

208 - 600V



SYSTEM RATINGS

Standby

Voltage (L-L)	240V**	240V**	208V**	240V**	480V**	600V**
Phase	1	1	3	3	3	3
PF	1.0	1.0	0.8	0.8	0.8	0.8
Hz	60	60	60	60	60	60
kW	60	60	60	60	60	60
kVA	60	60	75	75	75	75
AMPS	250	250	208	180	90	72
skVA@30%						
Voltage Dip	119	130	150	150	198	136
Generator Model*	362CSL1604	361CSL1613	361CSL1602	361CSL1602	361CSL1602	361PSL1633
Temp Rise	130°C/27°C	130°C/27°C	130°C/27°C	130°C/27°C	130°C/27°C	125°C/40°C
Connection	12 LEAD ZIG-ZAG	4 LEAD	12 LEAD LOW WYE	12 LEAD HI DELTA	12 LEAD HI WYE	4 LEAD WYE

Prime

Voltage (L-L)	240V	240V	208V	240V	480V	600V
Phase	1	1	3	3	3	3
PF	1.0	1.0	0.8	0.8	0.8	0.8
Hz	60	60	60	60	60	60
kW	55	55	55	55	55	55
kVA	55	55	68.75	68.75	68.75	68.75
AMPS	229	229	191	165	83	66
skVA@30%						
Voltage Dip	119	130	150	150	140	136
Generator Model*	362CSL1604	361CSL1613	361CSL1602	361CSL1602	361CSL1602	361PSL1633
Temp Rise	105°C/40°C	105°C/40°C	105°C/40°C	105°C/40°C	105°C/40°C	105°C/40°C
Connection	12 LEAD ZIG-ZAG	4 LEAD	12 LEAD LOW WYE	12 LEAD HI DELTA	12 LEAD HI WYE	4 LEAD WYE

* The Generator Model Number identified in the table is for standard C Series Configuration. Consult the factory for alternate configuration.

** UL2200 Offered

STANDARD FEATURES

- // EPA Tier 3 Certified
- // Engine-Generator Set Tested to ISO 8528-5 for Transient Response
- // UL2200, CSA Listing Offered
- // Accepts Rated Load in One Step Per NFPA 110
- // All engine-generator sets are prototype and factory tested
- // MTU Onsite Energy is a single source supplier
- // Global Product Support
- // 2 Year Standard Warranty
- // Custom Design for Any Application
- // 5030HF285 Diesel Engine
 - 3.0 Liter Displacement
 - Electronic Unit Pump Injection
 - 4-Cycle
- // Complete Range of Accessories
- // Permanent Magnet Generator (PMG) - Optional
 - Brushless, Rotating Field
 - 300% Short Circuit Capability
 - 2/3 Pitch Windings
- // Digital Control Panel(s)
 - UL Recognized, cULus, NFPA 110
 - Complete System Metering
 - LCD Display
- // Cooling System
 - Integral Set-Mounted
 - Engine Driven Fan

STANDARD EQUIPMENT

// Engine

Air Cleaner
 Oil Pump
 Full Flow Oil Filter
 Jacket Water Pump
 Thermostat
 Exhaust Manifold - Dry
 Blower Fan & Fan Drive
 Radiator - Unit Mounted
 Electric Starting Motor - 12V
 Governor - Electric Isochronous
 Base - Formed Steel
 SAE Flywheel & Bell Housing
 Charging Alternator - 12V
 Battery Box & Cables
 Flexible Fuel Connectors
 Flexible Exhaust Connection
 EPA Certified Engine

// Generator

NEMA MG1, IEEE and ANSI standards compliance for temperature rise and motor starting
 Sustained short circuit current of up to 300% of the rated current for up to 10 seconds
 Self-Ventilated and Drip-Proof
 Superior Voltage Waveform
 Digital, Solid State, Volts-per-Hertz Regulator
 No Load to Full Load Regulation

Brushless Alternator with Brushless Pilot Exciter
 4 Pole, Rotating Field
 130°C Standby Temperature Rise
 1 Bearing, Sealed
 Flexible Coupling
 Full Amortisseur Windings
 125% Rotor Balancing
 3-Phase Voltage Sensing
 ±1% Voltage Regulation
 100% of Rated Load - One Step
 3% Maximum Harmonic Content

// Digital Control Panel(s)

Digital Metering
 Engine Parameters
 Generator Protection Functions
 Engine Protection
 SAE J1939 Engine ECU Communications
 Windows-Based Software
 Multilingual Capability
 Remote Communications to our RDP-110 Remote Annunciator
 16 Programmable Contact Inputs
 7 Contact Outputs
 UL Recognized, cULus, CE Approved
 Event Recording
 IP 54 Front Panel Rating with Integrated Gasket
 NFPA110 Level Compatible

APPLICATION DATA

// Engine

Manufacturer	John Deere
Model	5030HF285
Type	4-Cycle
Arrangement	5 In-Line
Displacement: Cu In (lit)	186 (3.05)
Bore: in (cm)	3.4 (8.6)
Stroke: in (cm)	4.1 (10.5)
Compression Ratio	18.2:1
Rated RPM	1,800
Engine Governor	JDEC
Max Power: Standby: bhp (kWm)	96 (72)
Max Power: Prime: bhp (kWm)	87 (65)
Regulation	±.25%
Frequency	60 Hz
Air Cleaner	Dry

// Liquid Capacity (Lubrication)

Total Oil System: gal (lit)	2.96 (11.2)
Engine Jacket Water Capacity: gal (lit)	0.78 (2.9)
System Coolant Capacity: gal (lit)	4.08 (15.4)

// Electrical

Electric Volts DC	12
Cold Cranking Amps Under 0°F (-17.8°C)	750

// Fuel System

Fuel Supply Connection Size	3/8" NPT
Fuel Return Connection Size	3/8" NPT
Maximum Fuel Lift: ft (m)	10 (3)
Recommended Fuel	Diesel #2
Total Fuel Flow: gal/hr (lit/hr)	21.7 (82)

// Fuel Consumption

	STANDBY	PRIME
At 100% of Power Rating: gal/hr (lit/hr)	5 (18.9)	4.6 (17.4)
At 75% of Power Rating: gal/hr (lit/hr)	3.8 (14.4)	3.4 (12.9)
At 50% of Power Rating: gal/hr (lit/hr)	2.5 (9.5)	2.3 (8.3)

// Cooling - Radiator System

	STANDBY	PRIME
Ambient Capacity of Radiator: °F (°C)	122 (50)	122 (50)
Maximum Allowable Static		
Pressure on Rad. Exhaust: in. H ₂ O (kPa)	0.5 (0.12)	0.5 (0.12)
Water Pump Capacity: gpm (lit/min)	26 (100)	26 (100)
Heat Rejection to Coolant: BTUM (kW)	2,590 (45.5)	2,430 (42.7)
Heat Rejection to Air to Air: BTUM (kW)	723 (12.7)	598 (10.5)
Heat Radiated to Ambient: BTUM (kW)	728 (12.8)	595 (10.5)

// Air Requirements

	STANDBY	PRIME
Aspirating: *SCFM (m ³ /min)	186 (5.3)	179 (5.1)
Air Flow Required for Rad.		
Cooled Unit: *SCFM (m ³ /min)	5,795 (163)	5,795 (163)
Air Flow Required for Heat		
Exchanger/Remote Rad. based		
on 25°F Rise: *SCFM (m ³ /min)	1,642 (47)	1,341 (38)

* Air density = 0.0739 lbm/ft³ (1.184 kg/m³)

// Exhaust System

	STANDBY	PRIME
Gas Temp. (Stack): °F (°C)	972 (522)	941 (505)
Gas Volume at Stack		
Temp: CFM (m ³ /min)	484 (13.7)	459 (13)
Maximum Allowable		
Back Pressure: in. H ₂ O (kPa)	30 (7.5)	30 (7.5)
Minimum Allowable		
Back Pressure: in. H ₂ O (kPa)	16 (4)	16 (4)

WEIGHTS AND DIMENSIONS

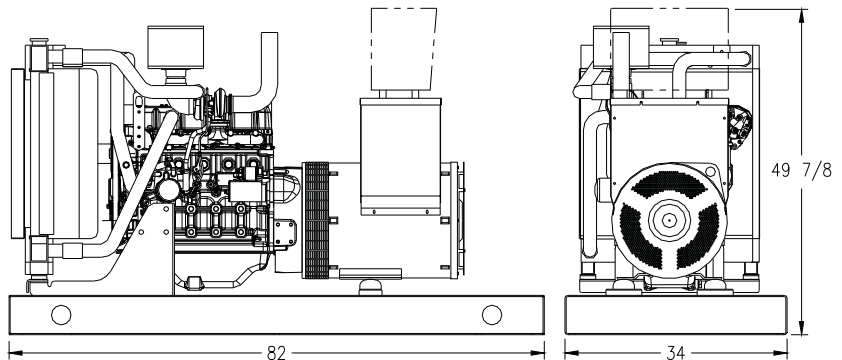

Drawing above for illustration purposes only, based on standard open power 480 volt generator. Lengths may vary with other voltages. Do not use for installation design.

System	Dimensions (L x W x H)	Weight (less tank)
OPU	82 x 34 x 49.9 in (2,080 x 860 x 1,270 mm)	1,639 lb (768 kg)

Weights and dimensions are based on open power units and are estimates only. Consult the factory for accurate weights and dimensions for your specific generator set.

SOUND DATA

Unit Type	Standby Full Load	Standby No Load	Prime Full Load	Prime No Load
OPU w/Critical Grade Muffler (dBA)	86.5	81	85	81
Sound Attenuated Enclosure (dBA)	78.5	73	77	73

Measurements for sound data are taken at 23 ft (7 m).

EMISSIONS DATA

NO _x + NMHC	CO	PM
3.48	0.68	0.097

All units are in g/hp-hr and are EPA D2 cycle values.

Emission levels of the engine may vary as a function of ambient temperature, barometric pressure, humidity, fuel type and quality, installation parameters, measuring instrumentation, etc. The data provided are laboratory results from one engine representing this rating. The data was obtained under controlled environmental conditions with calibrated instrumentation traceable to the United States National Bureau of Standards and in compliance with US EPA regulations found within 40 CFR Part 89. The weighted cycle value from each engine is guaranteed to be below the US EPA Standards at the US EPA defined conditions.

Materials and specifications subject to change without notice.

RATING DEFINITIONS AND CONDITIONS

- // Ambient capability factor at 984 ft (300 m). Consult your local MTU Onsite Energy Power Generation Distributor for other altitudes.
- // Standby ratings apply to installations served by a reliable utility source. The standby rating is applicable to varying loads for the duration of a power outage. No overload capability for this rating. Ratings are in accordance with ISO-3046/1, BS 5514, AS 2789, and DIN 6271.
- // Prime power ratings apply to installations where utility power is unavailable or unreliable. At varying load, the number of generator set operating hours is unlimited. A 10% overload capacity is available for one hour in twelve. Ratings are in accordance with ISO-8528/1, overload power in accordance with ISO-3046/1, BS 5514, AS 2789, and DIN 6271. For limited running time and base load ratings, consult the factory.
- // Deration Factor:
 - Altitude:** 0.5% per 1,000 ft (305 m) above sea level and 4% per 1,000 ft (305 m) above 10,000 ft (3,050 m).
 - Temperature:** 0.5% per 10°F (5.5°C) above 77°F (25°C).