

DIESEL ENGINE-GENERATOR SET

750-XC6DT2

750 ekW / 60 Hz / Standby
680 ekW / 60 Hz / Prime
208 - 4160V



SYSTEM RATINGS

Standby

Voltage (L-L)	208V**	240V**	480V**	600V**	4160V
Phase	3	3	3	3	3
PF	0.8	0.8	0.8	0.8	0.8
Hz	60	60	60	60	60
kW	750	750	750	750	750
kVA	937.5	937.5	937.5	937.5	937.5
AMPS	2602	2255	1128	902	130
skVA@30%					
Voltage Dip	2600	2600	2120	3050	1850
Generator Model*	574RSL4037	574RSL4037	573RSL4035	574RSS4278	574FSM4358
Temp Rise	130°C/27°C	130°C/27°C	130°C/27°C	125°C/40°C	130°C/27°C
Connection	12 LEAD LOW WYE	12 LEAD HI DELTA	12 LEAD HI WYE	4 LEAD WYE	6 LEAD WYE

Prime

Voltage (L-L)	208V	240V	480V	600V	4160V
Phase	3	3	3	3	3
PF	0.8	0.8	0.8	0.8	0.8
Hz	60	60	60	60	60
kW	680	680	680	680	680
kVA	850	850	850	850	850
AMPS	2359	2045	1022	818	118
skVA@30%					
Voltage Dip	2600	2600	2120	3050	1850
Generator Model*	574RSL4037	574RSL4037	573RSL4035	574RSS4278	574FSM4358
Temp Rise	105°C/40°C	105°C/40°C	105°C/40°C	105°C/40°C	105°C/40°C
Connection	12 LEAD LOW WYE	12 LEAD HI DELTA	12 LEAD HI WYE	4 LEAD WYE	6 LEAD WYE

* The Generator Model Number identified in the table is for standard C Series Configuration. Consult the factory for alternate configuration.

** UL2200 Offered

STANDARD FEATURES

- // EPA Tier 2 Certified
- // Engine-Generator Set Tested to ISO 8528-5 for Transient Response
- // UL2200, CSA Listing Offered
- // Accepts Rated Load in One Step Per NFPA 110
- // All engine-generator sets are prototype and factory tested
- // MTU Onsite Energy is a single source supplier
- // Global Product Support
- // 2 Year Standard Warranty
- // Custom Design for Any Application
- // 12V 2000 G85 Diesel Engine
 - 23.9 Liter Displacement
 - Electronic Unit Pump Injection
 - 4-Cycle
- // Complete Range of Accessories
- // Permanent Magnet Generator (PMG)
 - Brushless, Rotating Field
 - 300% Short Circuit Capability
 - 2/3 Pitch Windings
- // Digital Control Panel(s)
 - UL Recognized,  us, NFPA 110
 - Complete System Metering
 - LCD Display
- // Cooling System
 - Integral Set-Mounted
 - Engine Driven Fan

STANDARD EQUIPMENT

// Engine

Air Cleaners	Brushless Alternator with Brushless Pilot Exciter
Oil Pump	4 Pole, Rotating Field
Full Flow Oil Filter	130°C Standby Temperature Rise
Jacket Water Pump	1 Bearing, Sealed
Inter Cooler Water Pump	Flexible Coupling
Thermostats	Full Amortisseur Windings
Exhaust Manifold - Dry	125% Rotor Balancing
Blower Fan & Fan Drive	3-Phase Voltage Sensing
Radiator - Unit Mounted	±.25% Voltage Regulation
Electric Starting Motor - 24V	100% of Rated Load - One Step
Governor - Electric Isochronous	3% Maximum Harmonic Content
Base - Structural Steel	
SAE Flywheel & Bell Housing	
Charging Alternator - 24V	
Battery Box & Cables	
Flexible Fuel Connectors	
Flexible Exhaust Connection	
EPA Certified Engine	

// Generator

NEMA MG1, IEEE and ANSI standards compliance for temperature rise and motor starting	
Sustained short circuit current of up to 300% of the rated current for up to 10 seconds	
Self-Ventilated and Drip-Proof	
Superior Voltage Waveform	
Digital, Solid State, Volts-per-Hertz Regulator	
No Load to Full Load Regulation	
	// Digital Control Panel(s)
	Digital Metering
	Engine Parameters
	Generator Protection Functions
	Engine Protection
	SAE J1939 Engine ECU Communications
	Windows-Based Software
	Multilingual Capability
	Remote Communications to our RDP-110 Remote Annunciator
	16 Programmable Contact Inputs
	7 Contact Outputs
	UL Recognized,  us, CE Approved
	Event Recording
	IP 54 Front Panel Rating with Integrated Gasket
	NFPA110 Level Compatible

APPLICATION DATA

// Engine

Manufacturer	MTU
Model	12V 2000 G85TB
Type	4-Cycle
Arrangement	12-V
Displacement: Cu In (lit)	1,457 (23.9)
Bore: in (cm)	5.1 (13)
Stroke: in (cm)	5.9 (15)
Compression Ratio	16:1
Rated RPM	1,800
Engine Governor	ADEC
Max Power: Standby: bhp (kWm)	1,1193(890)
Max Power: Prime: bhp (kWm)	1,086 (810)
Regulation	±.25%
Frequency	60 Hz
Air Cleaner	Dry

// Liquid Capacity (Lubrication)

Total Oil System: gal (lit)	20.3 (77)
Engine Jacket Water Capacity: gal (lit)	29.1 (110)
After Cooler Water Capacity: gal (lit)	5.3 (20)
System Coolant Capacity: gal (lit)	72.4 (274)

// Electrical

Electric Volts DC	24
Cold Cranking Amps Under 0°F (-17.8°C)	1,750

// Fuel System

Fuel Supply Connection Size	3/4" NPT
Fuel Return Connection Size	1/4" NPT
Maximum Fuel Lift: ft (m)	10 (3)
Recommended Fuel	Diesel #2
Total Fuel Flow: gal/hr (lit/hr)	127 (480.7)

// Fuel Consumption

	STANDBY	PRIME
At 100% of Power Rating: gal/hr (lit/hr)	57.8 (218.8)	52.6 (199.1)
At 75% of Power Rating: gal/hr (lit/hr)	43.5 (164.6)	39.6 (149.9)
At 50% of Power Rating: gal/hr (lit/hr)	29.4 (111.3)	26.8 (101.4)

// Cooling - Radiator System

	STANDBY	PRIME
Ambient Capacity of Radiator: °F (°C)	104 (40)	104 (40)
Max. Restriction of Cooling Air, Intake, and Discharge Side of Rad.: in. H ₂ O (kPa)	0.5 (0.12)	0.5 (0.12)
Water Pump Capacity: gpm (lit/min)	220 (833)	220 (833)
After Cooler Pump Capacity: gpm (lit/min)	68 (257)	68 (257)
Heat Rejection to Coolant: BTUM (kW)	17,913 (315)	15,923 (280)
Heat Rejection to After Cooler: BTUM (kW)	15,354 (270)	13,932 (245)
Heat Radiated to Ambient: BTUM (kW)	4,805 (84.5)	4,350 (76.5)

// Air Requirements

	STANDBY	PRIME
Aspirating: *SCFM (m ³ /min)	2,331 (66)	2,225(63)
Air Flow Required for Rad. Cooled Unit: *SCFM (m ³ /min)	39,997 (1,132)	39,997 (1,132)
Air Flow Required for Heat Exchanger/Remote Rad. based on 25°F Rise: *SCFM (m ³ /min)	10,840 (307)	9,811 (278)

* Air density = 0.0739 lbm/ft³ (1.184 kg/m³)

// Exhaust System

	STANDBY	PRIME
Gas Temp. (Stack): °F (°C)	1,076 (580)	1,040 (560)
Gas Volume at Stack Temp: CFM (m ³ /min)	6,145 (174)	5,721 (160)
Maximum Allowable Back Pressure: in. H ₂ O (kPa)	34.1 (8.5)	34.1 (8.5)

WEIGHTS AND DIMENSIONS

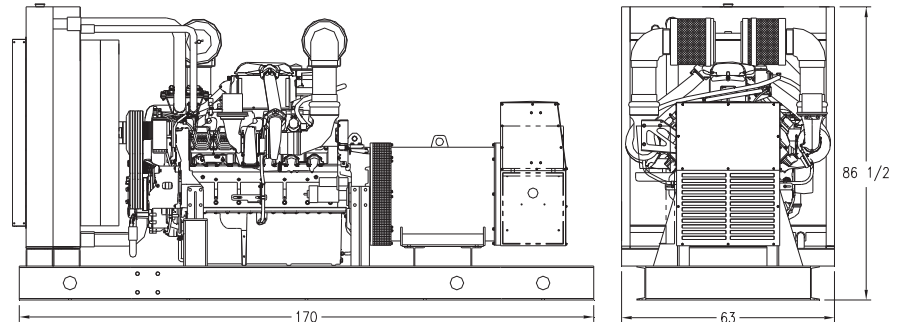

Drawing above for illustration purposes only, based on standard open power 480 volt generator. Lengths may vary with other voltages. Do not use for installation design.

System	Dimensions (LxWxH)	Weight (less tank)
OPU	170 x 63 x 86.5 in (4,320 x 1,600 x 2,200 mm)	12,328 lb (5,592 kg)

Weights and dimensions are based on open power units and are estimates only. Consult the factory for accurate weights and dimensions for your specific generator set.

SOUND DATA

Unit Type	Standby Full Load	Standby No Load	Prime Full Load	Prime No Load
OPU w/Critical Grade Muffler (dBA)	100	93	98.5	93
Sound Attenuated Enclosure (dBA)	92	85	90.5	85

Measurements for sound data are taken at 23 ft (7 m).

EMISSIONS DATA

NO _x + NMHC	CO	PM
4.03	0.81	0.09

All units are in g/hp-hr and are EPA D2 cycle values.

Emission levels of the engine may vary as a function of ambient temperature, barometric pressure, humidity, fuel type and quality, installation parameters, measuring instrumentation, etc. The data provided are laboratory results from one engine representing this rating. The data was obtained under controlled environmental conditions with calibrated instrumentation traceable to the United States National Bureau of Standards and in compliance with US EPA regulations found within 40 CFR Part 89. The weighted cycle value from each engine is guaranteed to be below the US EPA Standards at the US EPA defined conditions.

Materials and specifications subject to change without notice.

RATING DEFINITIONS AND CONDITIONS

- // Ambient capability factor at 984 ft (300 m). Consult your local MTU Onsite Energy Power Generation Distributor for other altitudes.
- // Standby ratings apply to installations served by a reliable utility source. The standby rating is applicable to varying loads for the duration of a power outage. No overload capability for this rating. Ratings are in accordance with ISO-3046/1, BS 5514, AS 2789, and DIN 6271.
- // Prime power ratings apply to installations where utility power is unavailable or unreliable. At varying load, the number of generator set operating hours is unlimited. A 10% overload capacity is available for one hour in twelve. Ratings are in accordance with ISO-8528/1, overload power in accordance with ISO-3046/1, BS 5514, AS 2789, and DIN 6271. For limited running time and base load ratings, consult the factory.
- // Deration Factor:
 - Altitude:** 0.75% per 328 ft (100 m) up to 4,921 ft (1,500 m). Contact factory for deration above 4,921 ft (1,500 m). Maximum altitude 8,694 ft (2,650 m).
 - Temperature:** 2.5% per 9°F (5°C) over 91°F (33°C) up to 104°F (40°C).